

Halter 12x12

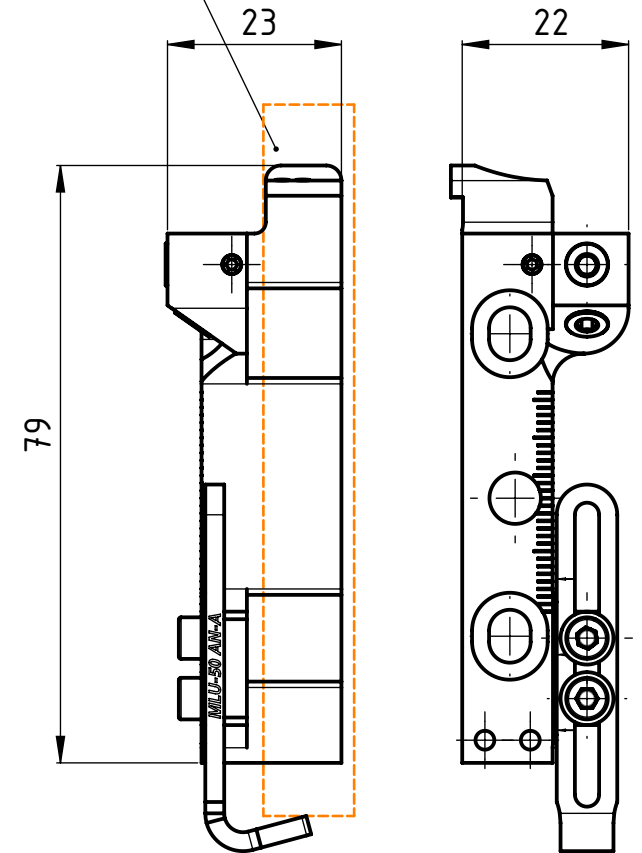

Lx=

Vorstandlänge des Werkzeuges für optimale Kühlung  
 Longueur d'outil pour un refroidissement optimal  
 Tool length for optimal cooling

Beschreibung

Multidec Lub Spannkeil

Artikel Bezeichnung

MLU TO-08 R-L IC-F

Zeichnungsnummer

MLU-88-02

**UTILIS**<sup>®</sup>  
 Tooling for High Technology

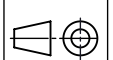

Index  
 -