

Holder 5/8"

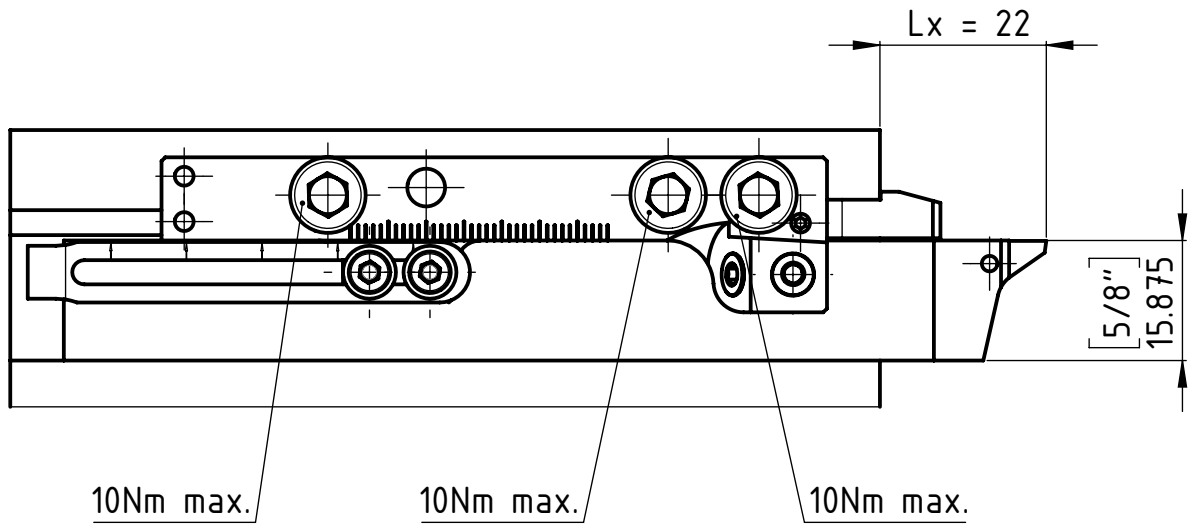

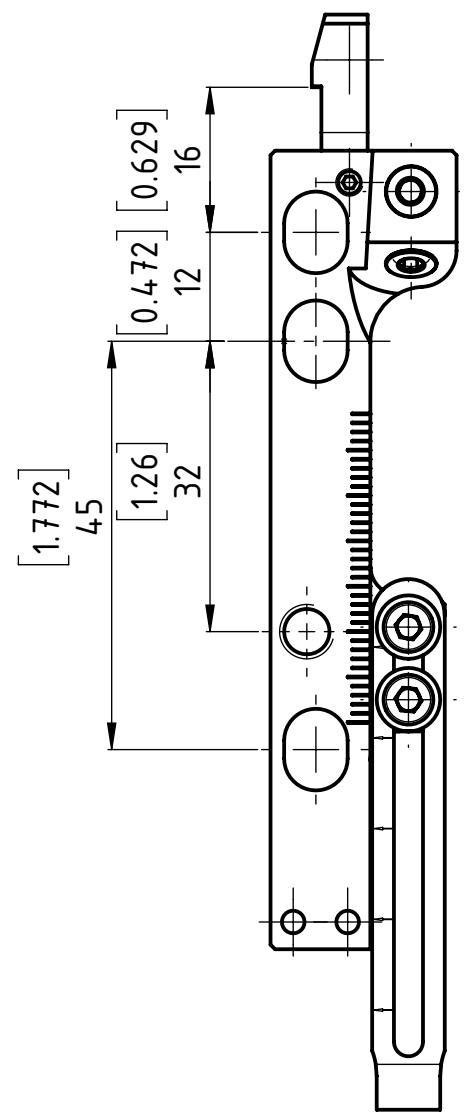
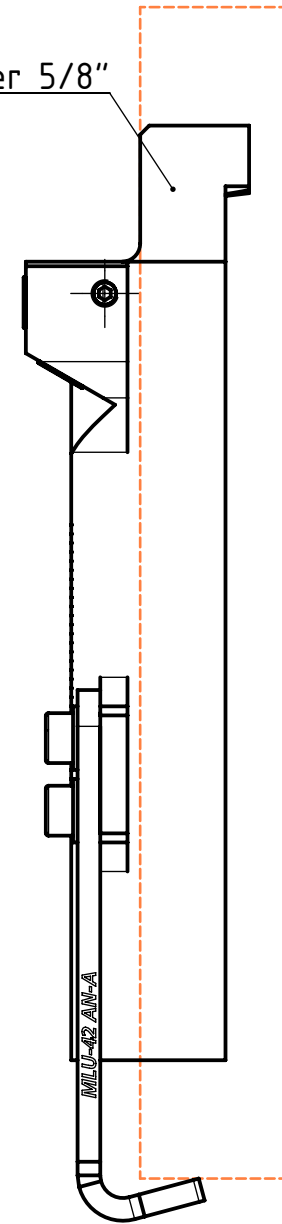

10Nm max.

10Nm max.

10Nm max.

Lx=
 Vorstandlänge des Werkzeuges für optimale Kühlung
 Longueur d'outil pour un refroidissement optimal
 Tool length for optimal cooling

| | | | |
|--------------------------------------|--|--------------------------------------|---|
| Beschreibung LUB Spannceil | Artikel Bezeichnung MLU CI-11 R-R IC-F | Zeichnungsnummer MLU-95-01 |   Index B |
|--------------------------------------|--|--------------------------------------|---|