

Machining direction →

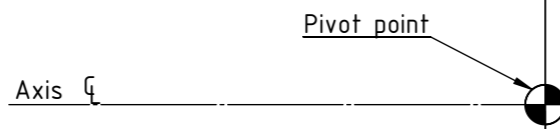

Please check and confirm the rotation direction!

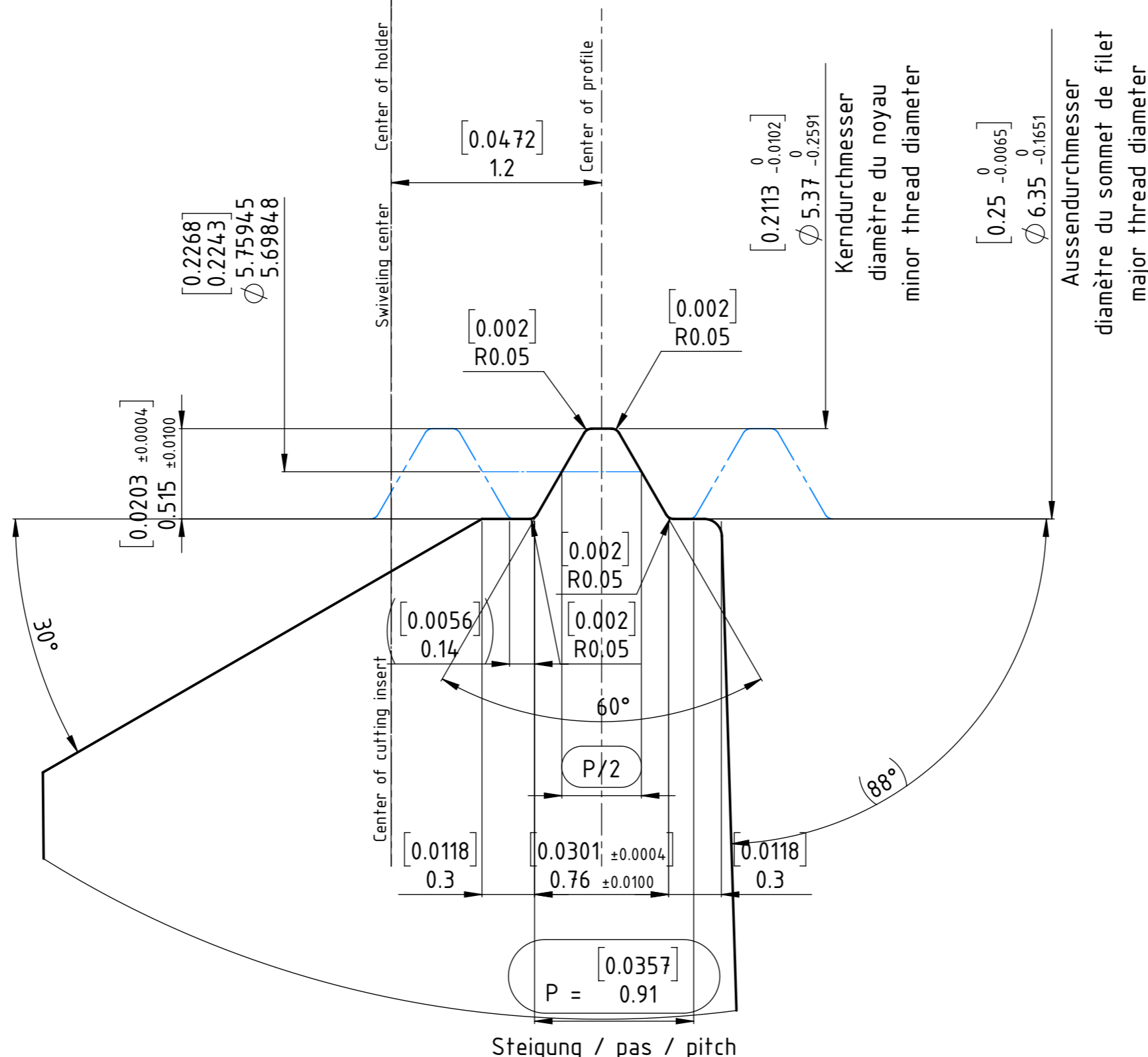
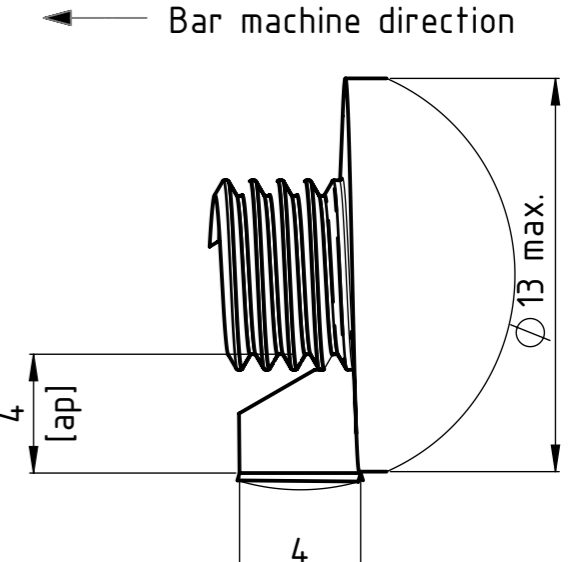
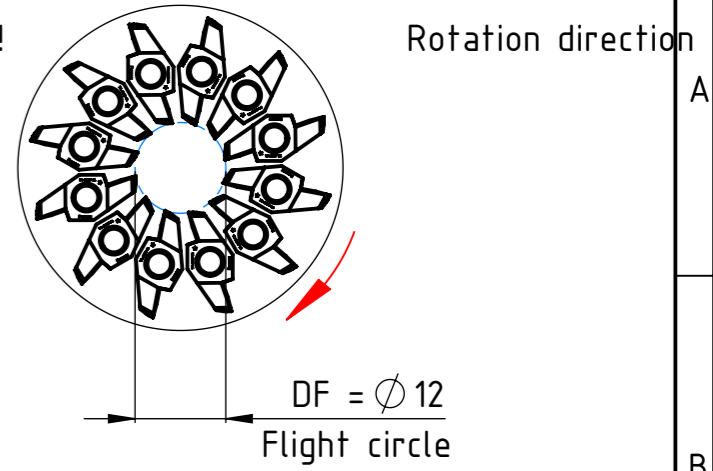

Number of starts/leads:  
1

Leadangle:  
2.87°

Original drawing:  
ASME B1.1-2019 / 1/4-28UNF-3A